

NOTES:

- 1 DIMENSIONS ARE IN INCHES [MILLIMETERS].
- 2 PUMP INLET CONNECTIONS MATE WITH 4-INCH VICTAULIC TYPE CLAMPED UNION
- 3 PUMP INLET MAY BE ROTATED IN 90° INCREMENTS.
- 4 PUMP DISCHARGE CONNECTIONS MATE WITH 3-INCH VICTAULIC TYPE CLAMPED UNION
- 5 TEFC GE 254/256TC MOTOR SHOWN, MOTOR DIMENSIONS WILL VARY WITH MANUFACTURER AND ARE SHOWN FOR REFERENCE ONLY.
- 6 PUMP AND MOTOR ADAPTER WILL ACCEPT NEMA 256TC FRAME 3565 RPM ELECTRIC MOTOR AND A FLEXIBLE COUPLING WITH THE END OF THE PUMP DRIVE SHAFT. THE 326TSC FRAME MOTORS MUST HAVE A BASE AND BE RIGIDLY MOUNTED. MOUNTING OF BEARING FRAME BASE IN A STRAIN-FREE MANNER IS OPTIONAL WITH 256TC FRAME MOTORS.
- 7 SEE PUMP INSTRUCTIONS P/N 1125317 FOR ADDITIONAL INFORMATION ON INSTALLATION, STARTUP, AND MAINTENANCE.

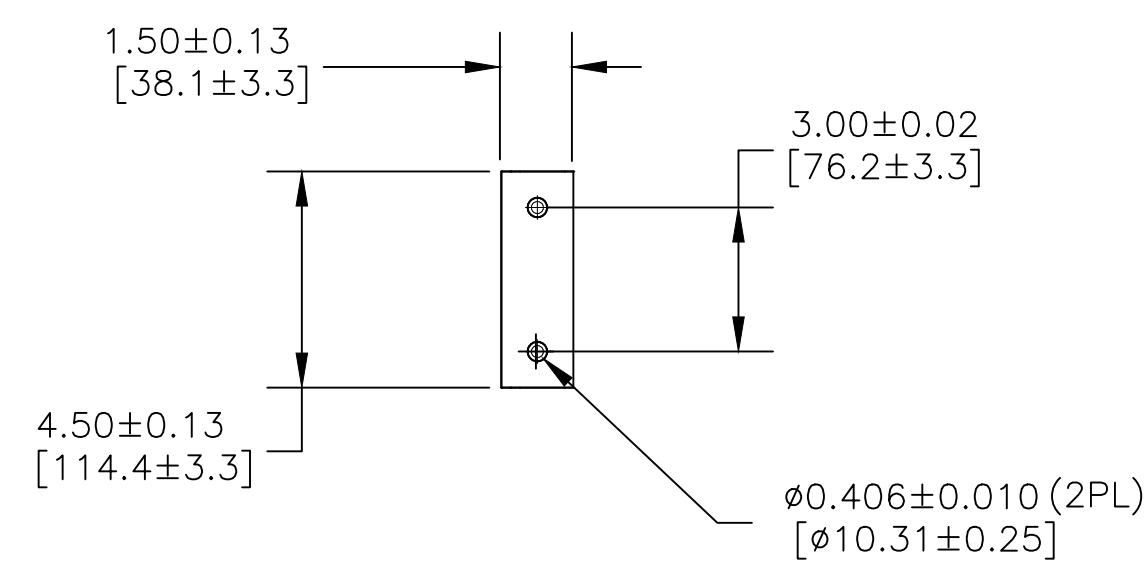
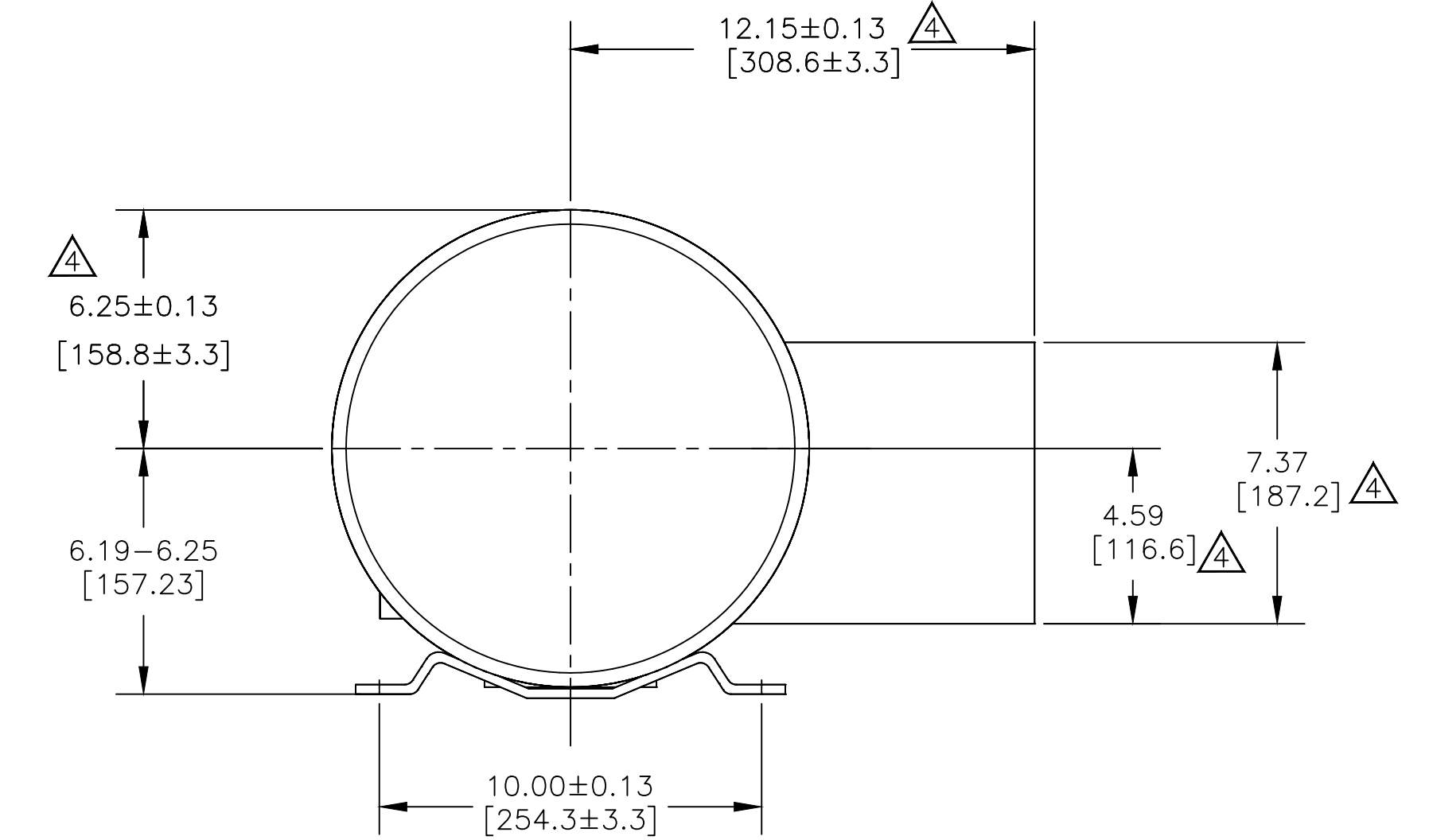
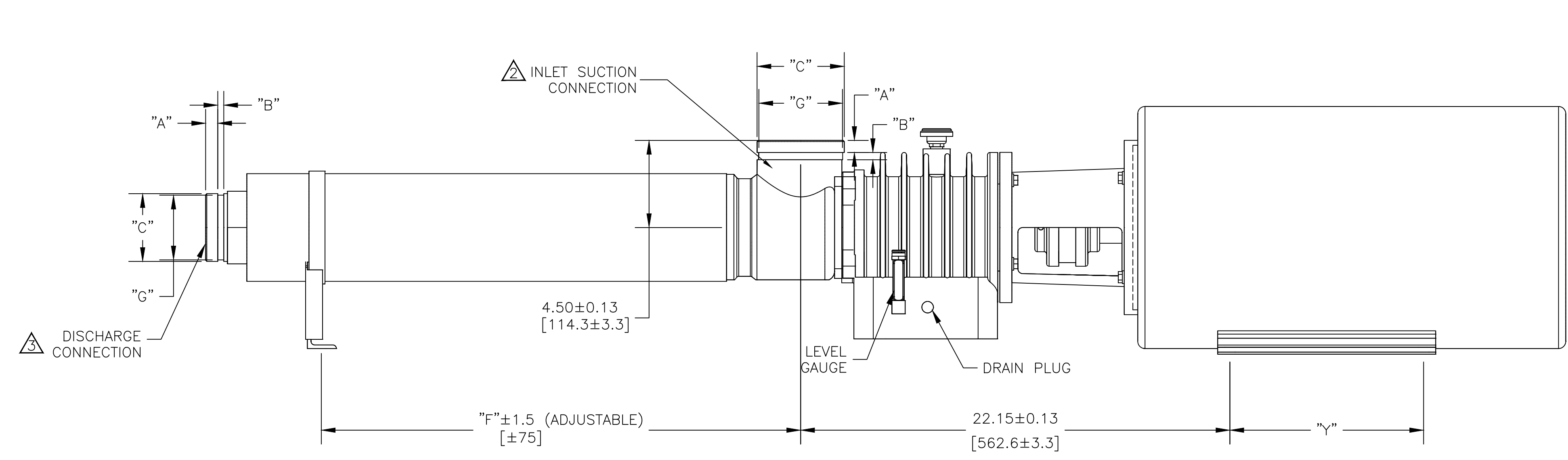
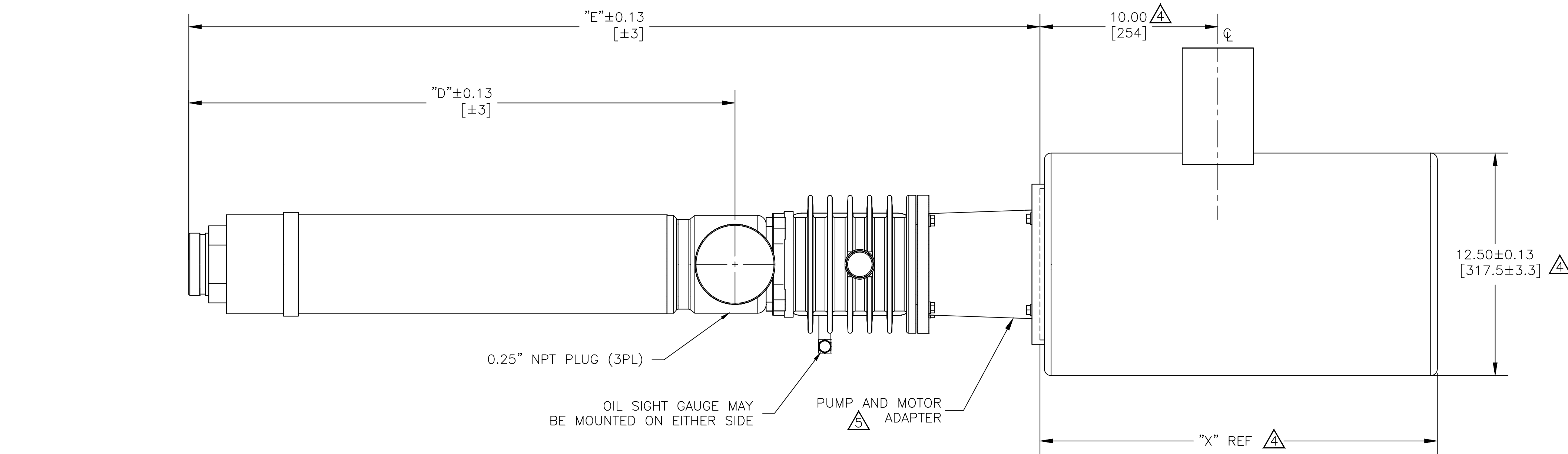

VICTAULIC® DIMENSIONS STANDARD 3" DISCHARGE CONNECTIONS			VICTAULIC® DIMENSIONS STANDARD 4" INLET CONNECTIONS		
ITEM	INCHES	MILLIMETERS	ITEM	INCHES	MILLIMETERS
"A"	0.625±0.031	15.88±0.78	"A"	0.625±0.031	15.88±0.78
"B"	0.312±0.031	7.94±0.78	"B"	0.375±0.031	9.53±0.78
"C"	3.500±0.031	88.90±0.78	"C"	4.500±0.031	114.30±0.78
"G"	3.344 ^{+0.000} _{-0.018}	84.94 ^{+0.00} _{-0.46}	"G"	4.334 ^{+0.000} _{-0.020}	110.08 ^{+0.00} _{-0.51}

NEMA FRAME SIZE	"X"		"Y"	
	INCHES	[MM]	INCHES	[MM]
254/256TC	22.34	567	10.00	254

MODELS		"D"	"E"	"F"
60HZ	50HZ	INCHES	INCHES	INCHES
AS22505KZB	AS22505KZB	30.71	47.86	24.71
AS30005KZB	AS30005KZB			
AS30004KZB	-			

REV	DESCRIPTION	ECO	DWN	APPR	APPR	DATE
D	VEOLIA REBRANDING	140586	HP	NL	NL	09 Jan 23
C	SUEZ REBRANDING	131562	TG	SR	MS	20 Sep 18
B	MODEL TABLE MODIFIED	15824	GMK	SS	MG	22JAN14
A	INITIAL RELEASE	14785	-	-	-	-

TOLERANCES UNLESS NOTED	
DECIMALS	ANGLES
.X 0.1	2
XX 0.03	FRAC
XXX 0.010	



CUSTOMER INFORMATION

DWG,TF,OUTLINE,AS22500KZB,AS
30000KZB,254/256TC NEMA MOTOR

DRAWING NUMBER				REVISION
1310317				D
REF.: -	DOC. OWNER: -	SCALE	SIZE	SHEET
PROJECT NO.	PART/MATERIAL NO.	1:4	D	1 OF 1